



### The GARVENS X Series

"X" for

"excellent build quality"

"extra-wide spaces for easy  
cleaning"

"screen size **XXL**"

## GARVENS X-series

The solution – for food and non-food applications

METTLER TOLEDO

# Perfect product inspection without compromise = **X** Series

- **X Series = configurable modular weighing systems with the latest technology**
- **Product inspection solutions – precisely tailored to your requirements**
- **Checkweighers and combinations**
- **HACCP-compliant design for size 3 models – with good looks!**

Designed by experienced expert teams, the new X-series checkweighers are the modern answer to harsh industrial requirements, for example in food producing companies.

Our In-Line Product Inspection specialists have developed a modular architecture for the most advanced product inspection, providing a system that's precisely tailored to your requirements.

**X** = optimised bespoke design

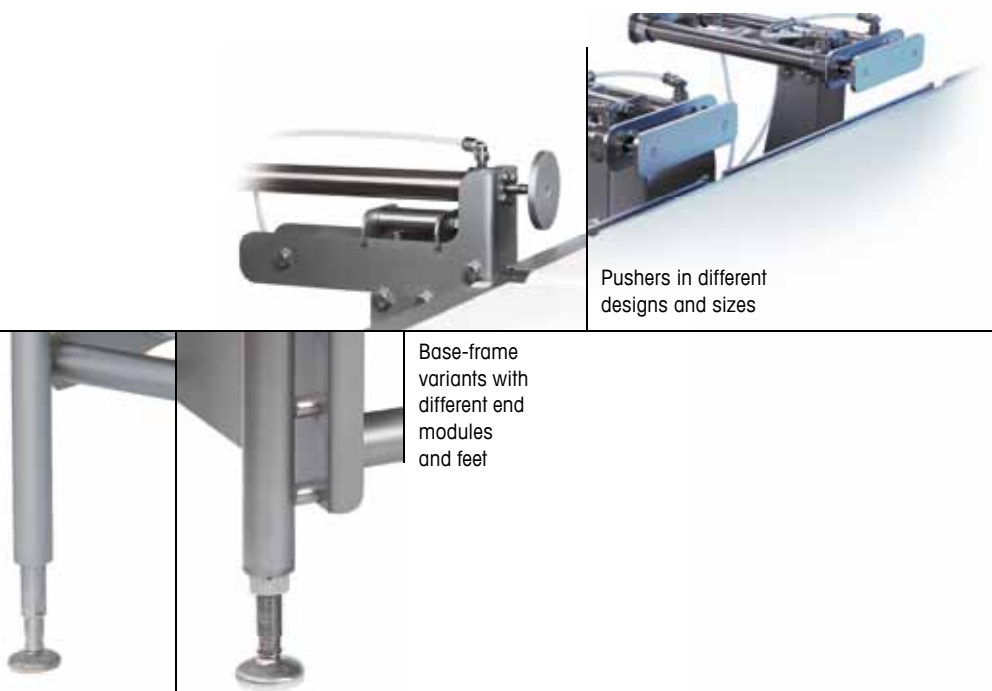

Pushers in different designs and sizes

Base-frame variants with different end modules and feet

XS3



XS3 CC H



XE3 H



XS2 MV



## Power wash

– the checkweigher is absolutely water-proof

"IP69K" models have demonstrated that they can also withstand regular cleaning with high-pressure cleaners, i.e. a water-volume flow of 14 to 16 litres per minute with a water temperature of  $80^{\circ}\text{C} \pm 5^{\circ}\text{C}$  and a pressure of 8 000kPa to 10 000kPa, directed at the checkweigher surfaces at 30 second cycles from angles of  $0^{\circ}$ ,  $30^{\circ}$ ,  $60^{\circ}$ ,  $90^{\circ}$  (IP69K test according to DIN 40050 Part 9 and DIN EN 60529).

Of course this is seldom required, as HACCP-compliant design minimises dirt traps with curved surfaces and minimal horizontal surfaces.

**X** = "IP69K" option for maximum water ingress protection

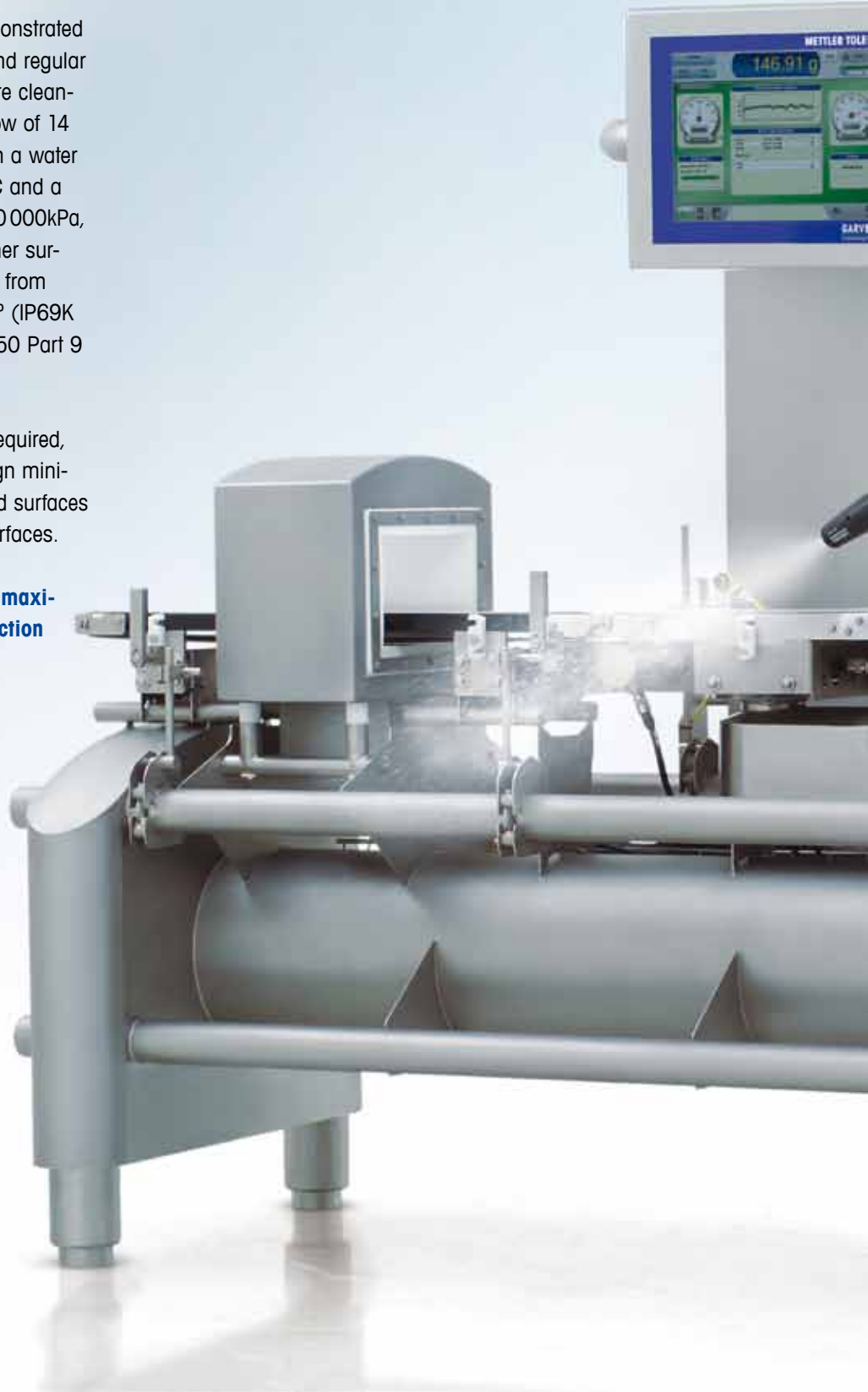

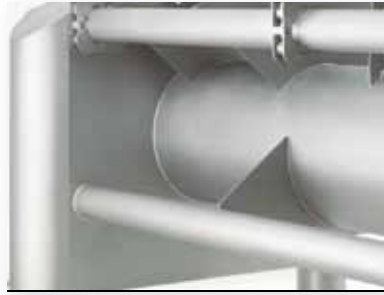

Full-perimeter weld seams ensure maximum hygiene

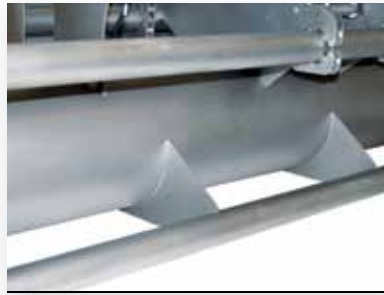

Easy to clean: open frame design ensures easy accessibility

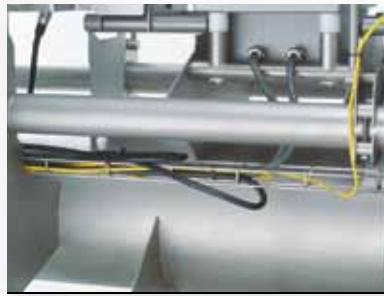

Innovative management system for cables and hoses: additional "lead through" channel along the base-frame



Minimal conveyor support clamping surfaces and open frame design for self-draining and ease of cleaning

## Tool-free belt replacement – easy to clean

Reduced dirt adhesion is ensured by the curved and chamfered surfaces. However, if thorough cleaning must be carried out on a regular basis, "X Series" models with easily removable conveyor belts are available: simply release the fastener – remove the belts – and the area beneath is accessible in a flash.

The prevention of bacteria traps is ensured by:

- a hygienic cable duct
- a reduced number of frame feet, even with longer structures
- full-perimeter weld seams
- minimised bearing surfaces on all superstructural parts.

**X = quick + easy cleaning**  
**= maximised uptime**





The quick-release conveyor fasteners ...



...and smart conveyor design...



...ensure easy dismantling and reassembly of the conveyor belt...



...and cleanliness even under the belt plate

# FreeWeigh.Net – the software system for statistical quality control

- Helps to optimise the fill process and minimise overfilling.
- Automates the quality management process in planning, filling and creation of the necessary reports.
- Simplifies quality control thanks to simple, universal operation and clear assignment of competence through classified and hierarchical system access.
- Permanent availability of on-line information at all system stations, with automatic alarm signals if values are exceeded.
- Extensive documentation and traceability.



MS SQL Server



Remote weighing stations



In-line checkweighers

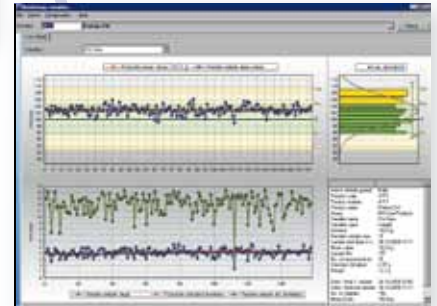

Monitoring



Planning





# X Series – also stands for: Integration of optional additional devices

With the X Series, you can maximise the capability of your production line: additional devices such as metal detectors for product inspection and/or laser markers for product labelling are centrally operated and controlled by the weighing terminal. Thanks to the typical integration capability of the X Series, further product inspection functions are also possible, for example

data code readers (e.g. barcode scanners), RFID readers and developments of the future.

The design of the X Series complies with the OMAC principle (Open Modular Architectural Controls).

PLC and PC connection options are available, as well as Ethernet network capability.

**X = simple, centralised operation**



OMAC machine status display shows overall system functioning



"Profile set-up" screen for creation and allocation of "user profiles"



Operation of the optional metal detector occurs entirely on the weighing terminal

# Operator guidance made simple!

## The new operating concept from GARVENS

- Large 15 inch display
- Maximum user-friendliness thanks to user profiles
- Contrast, size and brightness ensure optimal legibility
- Easy navigation thanks to intuitive software structure

The objective behind the development of the new user interface was to make operating the system even easier – with the help of object-oriented graphics and pictograms. The operator, the Production Manager and Quality Assurance Inspector will all quickly find what they're looking for.

Internet browser-style navigation. Do you like surfing the Web? We also provide convenient navigation aids for paging forwards and backwards like your Internet browser.

Additional "reminder functions": the last selection is presented to you the next time you open the menu, enabling you to find your way around even more easily.

Where am I at the moment? Look at the navigation sequence overview. It is present on the screen at all times and will help you to find where you are quickly and without any problems.



Stored printouts can be loaded onto the PrintStick and conveniently printed out in the office.



The easily visible and clear weight value curve provides real-time information on the production process.



The "Limits set-up" screen for setting the weight limits for product classification and sorting during weighing.

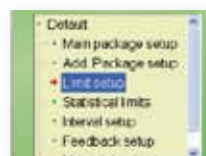



The large 15" screen of the new X Series terminal provides you with a clear, user-friendly operator interface.



All important information can be seen at a glance – thanks to the clearly arranged statistics screen.



1-2-3-4 ready! Calibrating a weigher has never been easier – thanks to on-screen instructions.

Each user can have his own password and can select the language he wants for the screen dialogue. The software switches all the operating dialogues to his "required language" as soon as he logs on to the weighing terminal.

Quick access module: Particular action screens can be selected for each user. These do not then require further navigation at a

later date, as they can be reached directly thanks to the "Quick Access" feature. An ingenious innovation, which makes operation even easier for everyone in a personal way.

**X = large screen**  
**= higher productivity**

**We have a team of service specialists covering checkweighing, metal detection and x-ray inspection technologies. We know it's vital that you have the best and most reliable service backup for the product inspection equipment you and your customers depend on.**

METTLER TOLEDO XXL Tailored Services provide unparalleled after-sales service and training for all the equipment we supply. With our highly trained field based service technicians and our technical support engineers we're ready to give you the support you deserve.



Professional assistance for your checkweighing, metal detection and x-ray inspection equipment is just a phone call away. A dedicated team of technical experts are at hand to answer your questions, whether it relates to a general enquiry or a complex problem. Our goal is to ensure you are obtaining the best from your equipment at all times. If a technician is required we can choose from a number of field based engineers to ensure we arrive on site within a time scale to meet your requirements.

[www.mt.com/garvens](http://www.mt.com/garvens)

For more information